



MPA 280-12 XL

12V-280Ah - Cyclic AGM Battery

APPLICATIONS

- Mobile Home Equipment
- Marine Applications
- Personal Carriers
- Cleaning Machines
- Utility Vehicles

SPECIFICATIONS

Nominal Voltage	12V	
Nominal capacity @20 hour rate	280Ah	
Capacity at 25°C	10 hour rate	240Ah
	5 hour rate	225Ah
	1 hour rate	150Ah
Shelf time @20°C up to 70%	in months	9
Internal resistance (at 1 KHz)	approx. 1,6 mΩ	
Operating temperature for (dis)charge	-15°C to + 40°C	

DIMENSIONS

Dimensions LxWxH (T) in mm	520x268x220 (226)
Weight	77kg (±2%)
Separator	AGM, Glass Matt
Case and cover	ABS
Terminal	M8
Torque setting (recommended)	M8 (Copper): 8 Nm
Maximum allowable torque value	M8 (Copper): 10 Nm

CHARGING

- Charging Voltage cycle use 14,4 to 14,9 Volt
- Float charge Voltage 13,6 to 13,8 Volt
- Charging current, minimum 30A - maximum 45A

CYCLE LIFE

To maximize the cycle life of the battery, we recommend to charge the battery fully after use. The total life of the battery, is very dependant on the correct charge and depth of discharge per cycle.

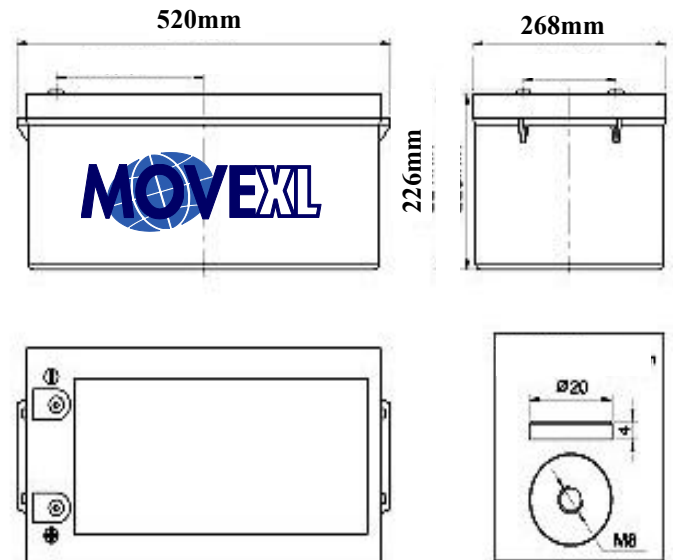

BATTERY LIFE UNDER CYCLIC USE

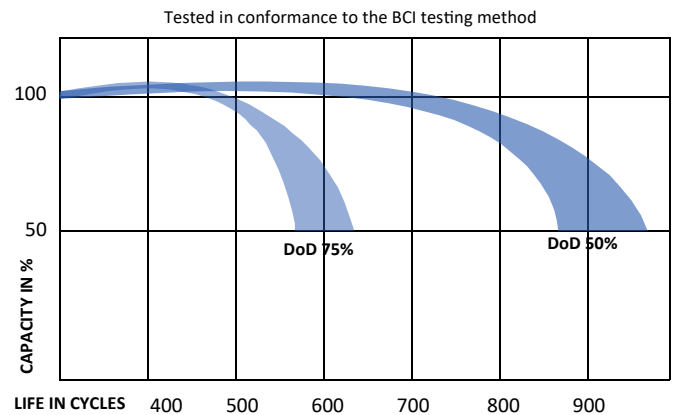

* Cycle life is measured with a discharge current 0,2C, charged 16h and rest capacity of 2/3 Cn