



MTG 40-12

12V-40Ah - GEL Battery

APPLICATIONS



Electric Vehicles (EV)
Home Mobility Equipment (HME)
Cleaning Equipment
Aerial Work Platforms (AWP)
All cyclic applications

SPECIFICATIONS



Nominal Voltage	12V	
80% DoD Voltage Cutoff	11.4V (1,90 VPC)	
Nominal capacity @20 hour rate	1.75VPC	40Ah
Capacity at 25°C	5 hour rate	34Ah
	1 hour rate	22Ah
Shelf time @20°C up to 70%	in months	12
Self discharge	per month	<3% (20°C)
Operating temperature for (dis)charge	-10°C to + 50°C	

DIMENSIONS



Dimensions LxWxH (T) in mm	198x166x171 (171)
Weight	13.3kg (±2%)
Terminal	M6
Terminal torque setting	6 Nm

CHARGING PROFILE (25°C in cyclic application)



IU Charging	I =	Min 4Amp / max. 8Amp
	U =	2.43 per cell
IUI Charging	I ¹ =	Min. 4mp / max. 8Amp
	U =	2.38V per cell
	I ² =	Min. 0,8Amp (for max. 4 hours to max. 2.65V per cell)
Float-Voltage	U-float =	2,30VPC
Temperature compensation is 3 Mv per degree°C up or down from 25°C		

CYCLE LIFE



To maximize the cycle life of the battery, we recommend to charge the battery fully after use. The total life of the battery, is very dependant on the correct charge and depth of discharge per cycle.

FEATURES



- Maintenance-free bloc batteries in Gel technology
- Stable high current performance for extreme conditions
- High-class patented safety valve
- Valve-regulated lead-acid battery filled with thixotropic gel
- Classified as a non-spillable battery
- 700 cycles according to IEC 254-1

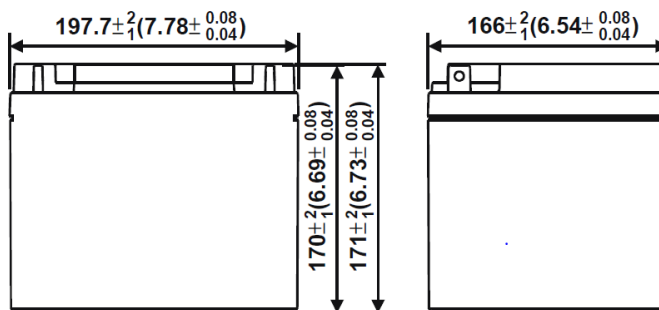
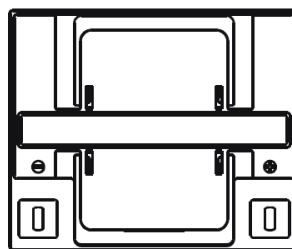

GEL Cycle Life vs Depth of Discharge at +25°C
Based on IEC 254-1

